

ABS- Articulating Back Support™

Size and Fit Adjustments:

Note directional blue arrow, position back support by rotating articulating arm into the body. Shoulder straps should **NOT** be touching shoulder blades (scapula) for maximum support and comfort. Secure desired position by permanently tightening top bolt with supplied hex key.

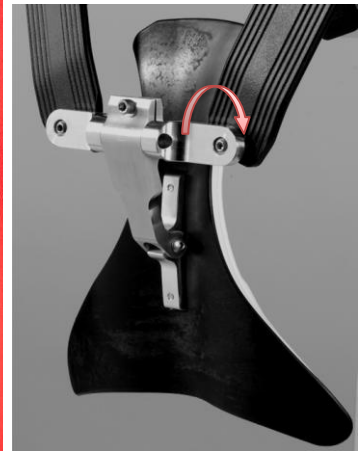

For larger upper body frame, remove ABS axels from shoulders straps. Rotate 180° as shown, replace securely.



STOP:

ABS comes preassembled with the shoulders straps preset for immediate use.



Do not loosen shoulder clamps.

(Read enclosed Instructions For Assembly for advanced shoulder adjustment and/or reversing AB plate if needed)

*Adjust Contour Hinge to size upper or lower body to fit requirements before fitting ABS back support**

**see other side*

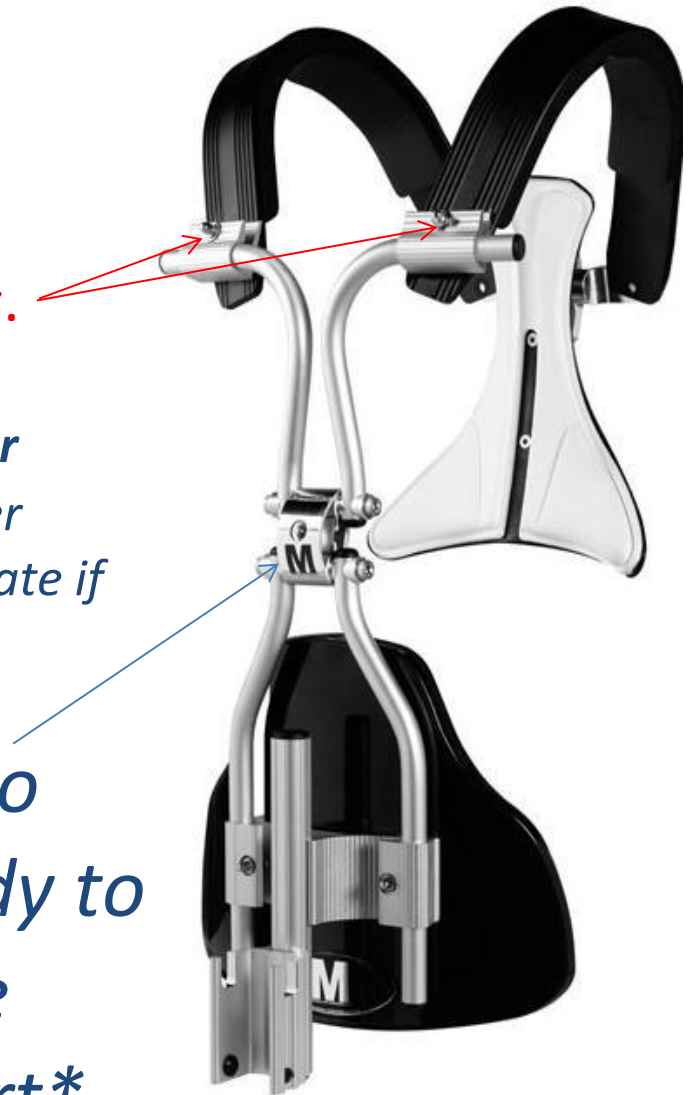

RM- TVHMSA